

Filter Housings

FRP Shell with Nylon Caps
30X-FRP



Parker Village Marine offers fiberglass filter housings specifically designed for seawater use. Simple but secure closure systems allow quick cartridge change. Aluminum collars are bonded to fiberglass shells offer superior corrosion resistance. The base and lid are nylon.

The housings fit VMT pleated cartridge elements of 30 square feet area. Available in 0.5, 1, 5, 20, and 100 micron ratings.

Contact Information:

Parker Hannifin Corporation
Filtration Group - Water Purification
2630 E. El Presidio Street
Carson, CA 90810

phone 310 608 5600
fax 310 608 5692
waterpurification@parker.com
www.villagemarine.com

www.parker.com/watermakers



ENGINEERING YOUR SUCCESS.

Filter Housings

FRP Shell with Nylon Caps
30X-FRP

DWG	Description	Part Number
	Filter Assembly	30-0647
1	Vessel Shell	30-0647-4
2	Base	M1157-1
3	Lid	M4353-2
4	O-Ring	30-0405
5	Nuts - Bottom	86-0022
6	Studs	86-0264
7	Washer	86-0006
8	Wingnut	86-0269
9	Bolt - Bottom	86-0260

Specifications	
Design Pressure*	80 psi
Test Pressure	120 psi
Inlet	1.5" FPT
Outlet	1.5" FPT
Height	15"/38cm
Diameter	13"/33 cm

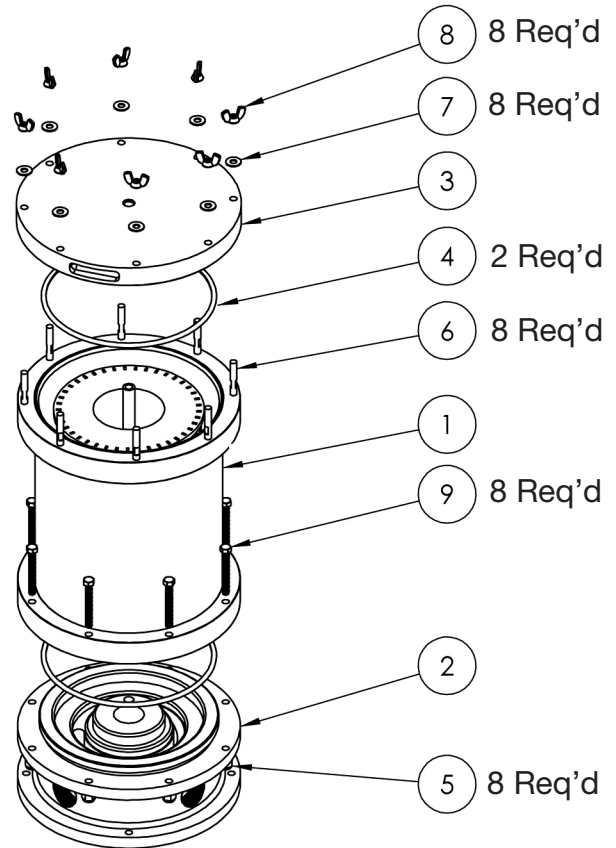

*Filter Housing Vessel is designed in accordance with ASME section x pressure vessel code.

To maintain peak performance always use genuine Parker Village Marine replacement parts.
We reserve the right to change our specifications or standards without notice.

