

# Chemical Dosing Systems

CDS-1



The Parker Village Marine Chemical dosing systems offer a chemical metering pump and tank. The system can be used in conjunction with the Village Marine PW and LT series watermakers. The chemical tank can be filled with chlorine, acid, or antiscalent chemical to enhance the watermakers membrane performance.

The Chemical Dosing Systems we manufacture are designed for perfection. Our range has gained the faith of our customer for their host of qualitative feature such as long service life, high performance and sturdy construction. Available in different specifications the entire range can also be customized as specified by the clients.

## Contact Information:

Parker Hannifin Corporation  
**Filtration Group/Village Marine**  
2630 E. El Presidio Street  
Carson, CA 90810

phone 310 608 5600  
fax 310 608 5692  
waterpurification@parker.com  
www.villagemarine.com  
www.parker.com/watermakers



ENGINEERING YOUR SUCCESS.

# Chemical Dosing Systems

## CDS-1

Village marine provides a complete range of Skid mounted chemical dosing pump systems. Chemical dosing systems are fully installed electrically and mechanically on a skid. You can then simply bolt the skid down and connect to your process.

Chemical Dosing Systems (CDS) are used in applications that require the mixing, storage and accurate dosing of specialized chemical reagents.

To acquire efficient and effective operation, chemicals are dosed into membrane treatment systems. To achieve optimal long-term plant performance, dosing the correct chemical at the optimum rate and in an effective manner is important. The chemicals that are commonly dosed into membrane systems are:

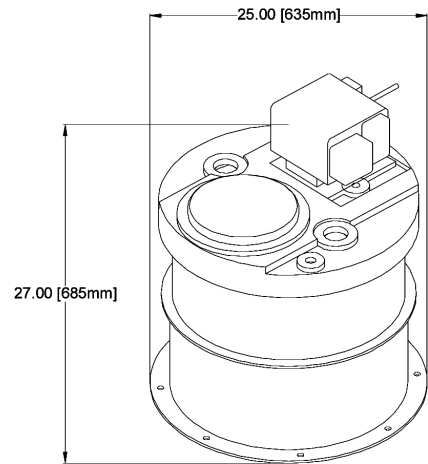
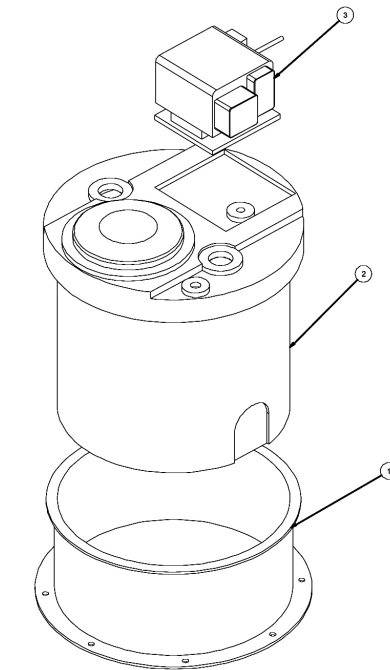

1	3	PUMP, CHLORINE, 120 VAC
1	2	TANK, PLASTIC
1	1	BASE, GRP
QTY	PC NO	DESCRIPTION

### Chlorine

The most common method of water disinfection and has been safely used for centuries. Excellent for potable water disinfection. Chemical dosing utilizes either sodium hypochlorite or calcium hypochlorite.

### pH Treatment

The most common method pH treatment. Chemical dosing utilizing citric acid.

### De-chlorination

The most common method de-chlorination. Chemical dosing utilizing sodium bisulfite.

### Antiscalent

The most common method de-chlorination. Chemical dosing utilizing sodium bisulfite.

Part Number	Description	Voltage	Gallons	Dimensions inch/cm (HxD)	Dry Weight lbs/kg
B644800010	Chemical dosing pump & tank assembly	230/1Ph/60 Hz	20	27"(68.5) x 25"(63.5)	40/18
B644800012		220/1Ph/50 Hz	20	27"(68.5) x 25"(63.5)	40/18
B644800011	Chemical dosing pump & tank assembly with flowmeter	230/1Ph/60 Hz	20	27"(68.5) x 25"(63.5)	42/19
B644800013		220/1Ph/50 Hz	20	27"(68.5) x 25"(63.5)	42/19

To maintain peak performance always use genuine Parker-Village Marine replacement parts. We reserve the right to change our specifications or standards without notice.

