

Pleasure Marine Christensen Yacht PWS 2000 Series Watermaker

Market Application Publication



Luxury yacht builder- Christensen Yachts

One of the nation's premier custom luxury yacht builders, Christensen Yachts, is located in the beautiful Pacific Northwest in Vancouver, Washington where their craftsmanship is world class. At their renowned American Shipyard they specialize in manufacturing custom mega yachts ranging from 160'-225'. Built with luxuries most celebrities could only imagine, including oversized hot tubs and state of the art gymnasiums, to intricate custom work with stone, glass, and wood throughout each vessel, Christensen Yachts never fails to impress their customers.

The goal of many of these yacht owners is to be completely self-sufficient on board so they can travel to just about anywhere, at any time, and still have all the luxuries and privacy they desire. One of the biggest challenges in meeting that goal is securing a reliable source of fresh water while out at sea.



Racor VMT PWS 2000
Swing Door Version

Contact Information:

Parker Hannifin Corporation
Racor Division/Village Marine Tec.
2630 E. El Presidio Street
Carson, CA 90810

phone 310 516 9911
fax 310 538 3048
racor@parker.com
www.villagemarine.com

www.parker.com/racor



Aqua Pro® Pump-708-5

Key Feature:

At the core of each PW series watermaker is the Aqua Pro® five-plunger high pressure pump:

- Titanium head for maximum corrosion resistance.
- Balanced drive for lowest noise and pulsation.
- Ceramic plunger and nylon valves for long service life.



ENGINEERING YOUR SUCCESS.

Why was Racor VMT chosen as the solution:

The team at Christensen Yachts works hand-in-hand with the owner of each new vessel, and many of the major components on board these magnificent yachts are meticulously chosen. This is why Racor Village Marine Tec. watermakers are chosen for each vessel.

Racor Village Marine Tec. has a long-standing, well-earned reputation of being the global leader in supplying the best reverse-osmosis water makers, especially when paired with exceptional factory support. Racor Village Marine Tec. manufactures over 95% of the components used in their water makers, along with the smallest footprint and customized designs. Racor engineers have worked closely with Christensen Yachts for many years in offering

systems to fit each new custom construction.

Because of VMT's 30 years experience in manufacturing watermakers, owners of Racor Village Marine Tec water makers can rest assured that they will have a reliable system for producing their own freshwater from the sea. With distribution and Parker support located around the globe, owners are never more than a port away from help.

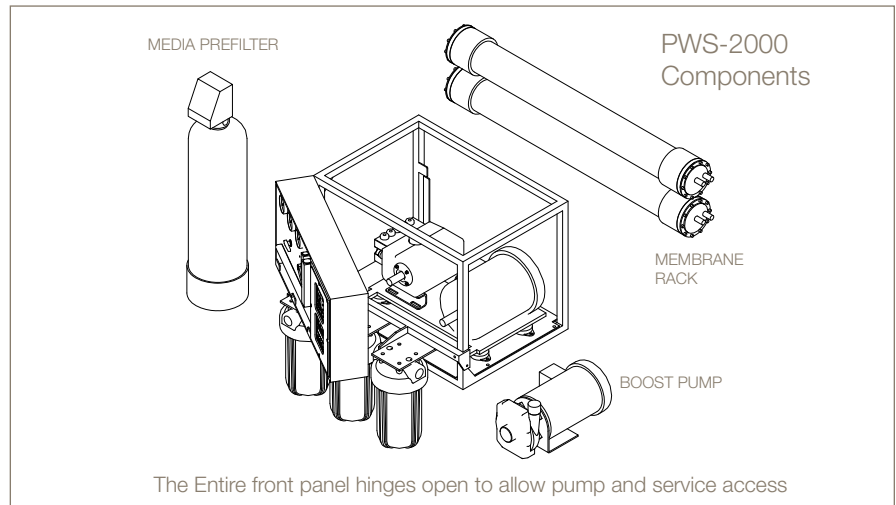

Model	Part Number	Capacity GPD m ³ /day	Power Volts/Phase/Hz/Amps	Dimensions inch/cm	Weight lbs/kg
PWV-800	90-8253 90-8220 90-8287	800 3.0	220/1/60/25 440/3/60/6.5 380/3/50/7	31/79 Wide 22/56 Deep 56/142 High	509/231
PWV-1200	90-8650 90-8651 90-8286	1200 4.5	220/1/60/25 440/3/60/6.5 380/3/50/7	31/79 Wide 22/56 Deep 56/142 High	526/239
PWV-2000	90-8546 90-8652 90-8275	2000 7.5	220/1/60/32 440/3/60/9 380/3/50/10	31/79 Wide 24/61 Deep 56/142 High	556/253
PWS-1200	90-8288 90-8289	1200 4.5	440/3/60/6.5 380/3/50/7	Frame W x D x H 27/69 x 24/61 x 16/41 Prefilters extend 14/35 below frame.	526/239
PWS-2000	90-8612 90-8290	2000 7.5	440/3/60/9 380/3/50/10	Boost pump, Media Filter and Membranes are modular	556/253

To maintain peak performance always use genuine Parker-Racor/Village Marine Tec. replacement parts. We reserve the right to change our specifications or standards without notice.