

Filter Housings

FRP Shell with Nylon Caps
100X-FRP



Racor Village Marine offers fiberglass filter housings specifically designed for seawater use. Simple but secure closure systems allow quick cartridge change. Aluminum collars are bonded to fiberglass shells offer superior corrosion resistance. The base and lid are nylon.

The housings fit VMT pleated cartridge elements of 100 square feet area. Available in 0.5, 1, 5, 20, and 100 micron ratings.

Contact Information:

Parker Hannifin Corporation
Racor Division/Village Marine Tec.
2630 E. El Presidio Street
Carson, CA 90810

phone 310 516 9911
fax 310 538 3048
racor@parker.com
www.villagemarine.com

www.parker.com/racor



ENGINEERING YOUR SUCCESS.

Filter Housings

FRP Shell with Nylon Caps

100X-FRP

DWG	Description	Part Number
	Filter Assembly	30-4353
1	Vessel Shell	M4353-4
2	Base	M1157-1
3	Lid	M4353-2
4	O-Ring	30-0405
5	Nuts - Bottom	86-0022
6	Studs	86-0264
7	Washer	86-0006
8	Wingnut	86-0269
9	Bolt - Bottom	86-0260

Specifications	
Design Pressure*	80 psi
Test Pressure	120 psi
Inlet	1.5" FPT
Outlet	1.5" FPT
Height	33"/84 cm
Diameter	13"/33 cm

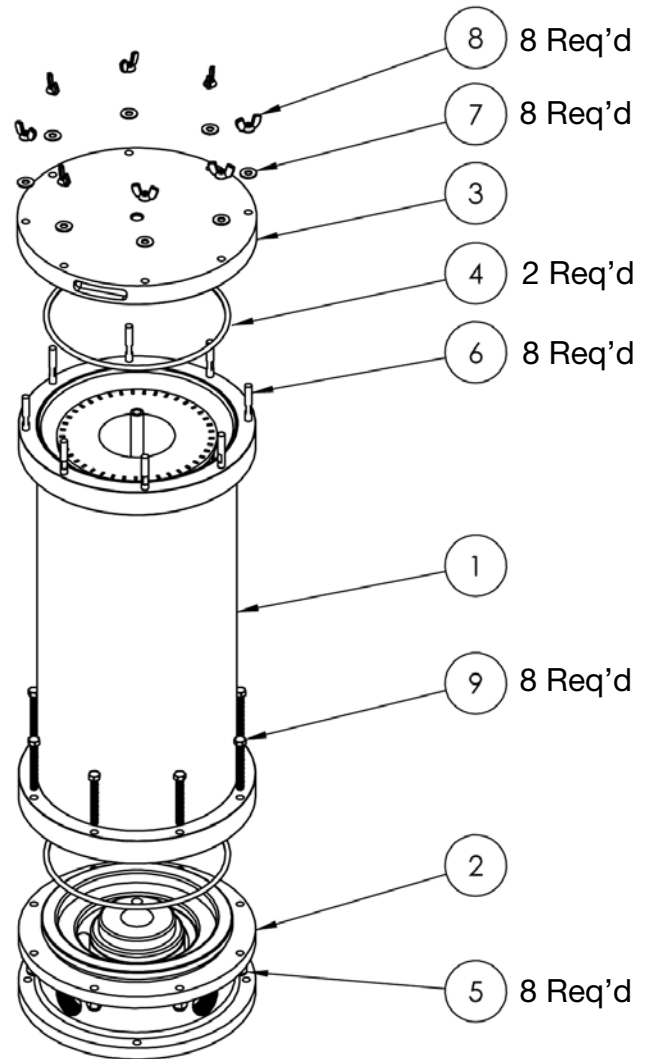

*Filter Housing Vessel is designed in accordance with ASME section x pressure vessel code.

To maintain peak performance always use genuine Parker Racor Village Marine replacement parts.
We reserve the right to change our specifications or standards without notice.